

8/1 ISLAND&MURALES

178



POS

Accessorio
optionalRefrigeratori per bibite / Coolers for soft drinks / Réfrigérateurs
pour boissons / Kühlende Strukturen für Getränke /
Refrigerador para bebidas





































Disegni Tecnici: PAG. 180



POLARIS

Espositori per gelati e surgelati / Ice cream and frozen food display units / Exposants pour glaces
et surgelés / Aussteller für Eis und Tiefkühlkost / Expositores para helados y productos congelados

Disegni Tecnici: PAG. 180

Modello Model Modèle Modell Modelo	Potenza Power Puissance Gesamtleistung Potencia	Tensione Tension Tension Spannung Tension	Temperatura Temperature Temperatur Temperatur Temperatura	Refrigerazione Refrigeration Refrigeration Kühlung Refrigeracion	Sbrinamento Defrosting Degivrage Enteisung Desescarche	Gas refrigerante Cooling gas Gaz réfrigérant Kühlgas Gas refrigerante	Capacità Capacity Capacité Gerraumvolumen Capacidad	Peso netto Net weight Poids net Nettogewicht Peso neto
 POS	 Watt 320	 230v/1/50Hz	 °C +2/+8			 R 134a	 Lt. 80	 Kg 51
 POLARIS 185	 Watt 500	 230v/1/50Hz	 °C -12/-22			 R 404a	 Lt. 689	 Kg 110
 POLARIS 210	 Watt 620	 230v/1/50Hz	 °C -12/-22			 R 404a	 Lt. 797	 Kg 125
 POLARIS 250	 Watt 620	 230v/1/50Hz	 °C -12/-22			 R 404a	 Lt. 970	 Kg 145

Dati di collaudo - Test details - Détails d'essai - Prüfungsergebnisse - Datos de ensayo - MAX = (30°C - % U.R. 55)

Espositori per gelati e surgelati / Ice cream and frozen food display units / Expositors pour glaces et surgelés / Aussteller für Eis und Tiefkühlkost / Expositores para helados y productos congelados



IKG JUMBO 250 AN



IKG JUMBO 150 AN

IKG JUMBO 200 AN



Cesti
Baskets
Paniers
Körbe
Canastas



Disegni Tecnici: PAG. 180

Modello Model Modèle Modell Modelo	Potenza Power Puissance Gesamtleistung Potencia	Tensione Tension Tension Spannung Tension	Temperatura Temperature Temperature Temperatur Temperatura	Refrigerazione Refrigeration Refrigeration Kuehlung Refrigeracion	Sbrinamento Defrosting Degivrage Enteisung Desescarche	Gas refrigerante Cooling gas Gaz réfrigérant Kühlgas Gas refrigerante	Capacità Capacity Capacité Gerraumvolumen Capacidad	Peso netto Net weight Poids net Nettogewicht Peso neto
IKG JUMBO 150 AN	Watt 410	230v/1/50Hz	°C -15/-18			R 134a	Lt. 459	Kg 81
IKG JUMBO 200 AN	Watt 594	230v/1/50Hz	°C -15/-18			R 134a	Lt. 652	Kg 105
IKG JUMBO 250 AN	Watt 594	230v/1/50Hz	°C -15/-18			R 134a	Lt. 805	Kg 125

Dati di collaudo - Test details - Détails d'essai - Prüfungsergebnisse - Datos de ensayo - MAX = (30°C - % U.R. 55)

EUROLINE

BIRRA

MERCATI SPECIALI

LABORATORI PASTICCERIA

RISTORAZIONE

PIZZERIA

ESPOSIZIONE

SUPERMERCATI

HYPERMARKET

10

ATTREZZATURE COMPLEMENTARI

POS

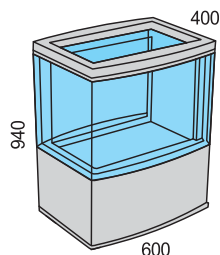

Evaporazione acqua di sbrinamento
Evaporation of defrost water
Evaporation eau de dégivrage
verdunsten des Auftauwassers
Evaporación agua descongelaçión



0,50 lt. Pet bottles N° 72
0,33 lt. Cans N° 96

Esterno interno in PVC
Inside outside of PVC
Ausseres und Inneres aus PVC
Extérieur et intérieur en PVC
Exterior interior en PVC

Di serie senza pubblicità
Series Standard with no advertisement
De série sans publicité
Serienmässig ohne Reklame
De serie sin publicidad

POLARIS

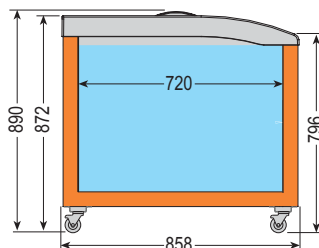
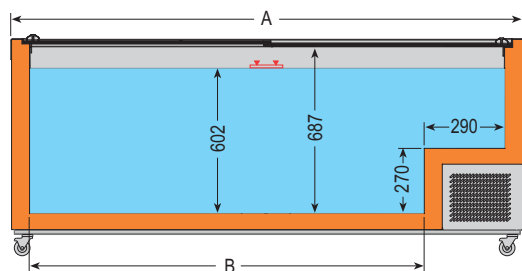

DIMENSIONI / SIZE / DIMENSIONS / MABE / MEDIDAS

	A (mm)	B (mm)
POLARIS 185	1858	1430
POLARIS 210	2108	1680
POLARIS 250	2508	2080



Isolamento con 65 mm di spessore
Insulation thickness 65 mm.
Isolation avec 65 mm d'épaisseur
Isolierung durch eine Dicke von 65 mm.
Aislamiento de 65 mm de espesor

IKG JUMBO AN

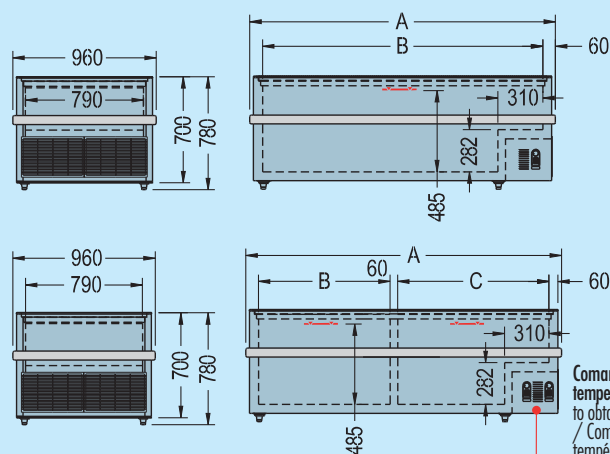

IKG JUMBO 150 AN
IKG JUMBO 200 AN

IKG JUMBO 250 AN

Comandi separati per ottenere diverse temperature nelle due celle / Separate controls to obtain different temperatures in two storages / Commandes séparates pour obtenir températures différentes dans les deux cellules / Separate Steuerungen um verschiedene Temperaturen in den zwei Zellen zu erzielen / Mandos separados para obtener temperaturas diferentes en las dos celdas

Esterno in lamiera zincata rivestita in PVC
Exterior made of galvanized sheet covered in PVC / Extérieur en tôle galvanisée recouverte de PVC / Außenseite in verzinktem Blech mit PVC überzogen / Exterior de chapa galvanizada revestida de PVC

Interno in lamiera rivestita in PVC atossico
Interior made of sheet covered in non toxic PVC / Intérieur en tôle recouvert de PVC atoxique / Innenseite aus Blech mit ungiftigem PVC überzogen / Interior de chapa revestida de PVC atóxico

Congelamento veloce
Quick freezing / Congélation rapide
Schnelles Einfrieren / Congelamiento rápido

Scarico di liquidi
Discharge of liquids / Ecoulement de liquides / Flüssigkeitsentladung / Desagüe de líquidos

Centralina elettronica per il controllo della temperatura interna
Electronic cabinet to check internal temperature / Central électronique pour le contrôle de la température interne / Elektronisches Steuergehäuse zur Kontrolle der Innentemperatur / Centralita electrónica para controlar temperatura interna

Forniti con 1 paio di coperchi scorrevoli in vetro termico
Provided with 1 pair of sliding covers made of thermic glass / Fournis avec 1 paire de couvercles coulissants en verre thermique / Mit 1 Paar länglichen Schiebedeckel aus Wärmeschutzglas geliefert / Provistos con 1 par de tapas corredizas de cristal térmico
IKG JUMBO 150 AN
IKG JUMBO 200 AN

Forniti con 2 paio di coperchi scorrevoli trasversali in vetro termico
Provided with 2 pairs of transversal sliding covers made of thermic glass / Fournis avec 2 paires de couvercles coulissants transversaux en verre thermique / Mit 2 Paar queren Schiebedeckel aus Wärmeschutzglas geliefert / Provistos con 2 pares de tapas corredizas transversales de cristal térmico
IKG JUMBO 250 AN

DIMENSIONI / SIZE / DIMENSIONS / MABE / MEDIDAS

	A (mm)	B (mm)	C (mm)
IKG JUMBO 150 AN	1550	1375	—
IKG JUMBO 200 AN	2050	1880	—
IKG JUMBO 250 AN	2505	1140	1140

	Nr. cesti di serie No. serial baskets Nr. paniers de serie Nr. serien Koerbe Nr. canastos de serie	Capacità totale cesti Total capacity of baskets Capacité totale paniers Totale kapazität Koerbe Capacidad total canastos
IKG JUMBO 150 AN	N° 1	N° 3
IKG JUMBO 200 AN	N° 1	N° 5
IKG JUMBO 250 AN	N° 1	N° 7

EUROLINE

BIRRA

MERCATI SPECIALI

LABORATORI PASTICCERIA

RISTORAZIONE

PIZZERIA

ESPOSIZIONE

SUPERMERCATI

HYPERMARKET

ATTREZZATURE COMPLEMENTARI

Espositori per gelati e surgelati / Ice cream and frozen food display units / Exposants pour glaces et surgelés / Aussteller für Eis und Tiefkühlkost / Expositores para helados y productos congelados



PROMOXION 130

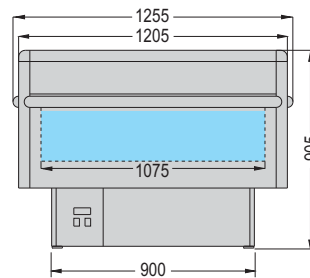
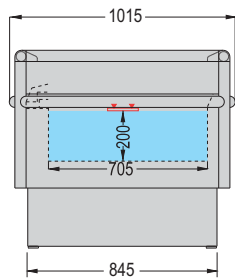

Evaporazione acqua di sbrinamento
Evaporation of defrost water
Evaporation eau de dégivrage
verdunsten des Auffauwassers
Evaporación agua descongelación



Evaporatore in cella
Inside vaporator
Evaporateur intérieur
Verdampfer in der Velle
Evaporador interior de la cámara

Sbrinamenti nelle 24 h.
Defrosting in the 24 h.
Dégivrages dans les 24 heures
Aufthauen innerhalb 24 Stunden
Descongelación en las 24 h.
N°4



Luce interna
Internal light
plafonnier
Innenlicht
Luz interior

Superficie espositiva
Display surface
Surfaces d'exposition
Ausstellungsoberfläche
Superficie expositiva
PROMOXION 130 = m² 0,83

OPTIONAL:



Kit ruote con e senza freno
Kit wheels with and without brake
Kit roulettes avec et sans frein
Kit rollen mit und ohne bremse
Kit ruedas con y sin freno



Kit griglie + clips
Kit grille + clips
Kit grills + support
Kit Gitter + Halterung
Kit grilles + soporte

Modello
Model
Modèle
Modell
Modelo

Potenza
Power
Puissance
Gesamtleistung
Potencia

Tensione
Tension
Tension
Spannung
Tension

Temperatura
Temperature
Temperature
Temperatur
Temperatura

Refrigerazione
Refrigeration
Refrigeration
Kuehlung
Refrigeracion

Sbrinamento
Defrosting
Dégivrage
Enteisung
Desescarche

Gas refrigerante
Cooling gas
Gaz réfrigérant
Kühlgas
Gas refrigerante

Capacità
Capacity
Capacité
Gerraumvolumen
Capacidad

Peso netto
Net weight
Poids net
Nettogewicht
Peso neto



PROMOXION 130 NT



Watt 900



230v/1/50Hz



°C -12/-22



R 404a



Lt. 165



Kg 128



PROMOXION 130 PT



Watt 700



230v/1/50Hz



°C +1/+10



R 404a



Lt. 165



Kg 128

EUROLINE
BIRRA
MERCATI SPECIALI
LABORATORI PASTICCERIA
RISTORAZIONE
PIZZERIA
ESPOSIZIONE
SUPERMERCATI
HYPERMARKET
10
ATTREZZATURE COMPLEMENTARI

SKY MASTER 180



Illuminazione interna
Internal lighting
Eclairage interne
Innenbeleuchtung
Iluminación interna



SURGELATI

OPTIONALS:
Separatori per alimenti
Food partitions
Intercalaires pour aliments
Lebensmittelunterteilungen
Separadores de alimentos

Modello Model Modèle Modell Modelo	Potenza Power Puissance Gesamtleistung Potencia	Tensione Tension Tension Spannung Tension	Temperatura Temperature Temperature Temperatur Temperatura	Refrigerazione Refrigeration Refrigeration Kuehlung Refrigeracion	Sbrinamento Defrosting Degivrage Enteisung Desescarche	Gas refrigerante Cooling gas Gaz réfrigérant Kühlgas Gas refrigerante	Capacità Capacity Capacité Gerraumvolumen Capacidad	Peso netto Net weight Poids net Nettogewicht Peso neto
SKY MASTER 180	Watt 762	230v/1/50Hz	°C -15/-18			R 134a	Lt. 370	Kg 110
SKY MASTER 180 COMBI	Watt 762	230v/1/50Hz	°C -15/-18 °C -1/+5			R 134a	Lt. 370	Kg 110

Dati di collaudo - Test details - Détails d'essai - Prüfungsergebnisse - Datos de ensayo - MAX = (30°C - % U.R.55)

EUROLINE

BIRRA

MERCATI SPECIALI

LABORATORI PASTICCERIA

RISTORAZIONE

PIZZERIA

ESPOSIZIONE

SUPERMERCATI

HYPERMARKET

ATTREZZATURE COMPLEMENTARI

SKY 150 P



SKY 200 S



Modello
Model
Modèle
Modell
Modelo

Potenza
Power
Puissance
Gesamtleistung
Potencia

Tensione
Tension
Tension
Spannung
Tension

Temperatura
Temperature
Temperature
Temperatur
Temperatura

Refrigerazione
Refrigeration
Refrigeration
Kuehlung
Refrigeracion

Sbrinamento
Defrosting
Degivrage
Enteisung
Desescarche

Gas refrigerante
Cooling gas
Gaz réfrigérant
Kühlgas
Gas refrigerante

Capacità
Capacity
Capacité
Gerraumvolumme
Capacidad

Peso netto
Net weight
Poids net
Nettogewicht
Peso neto

SKY 150 P	Watt 600	230v/1/50Hz	°C -15/-18			R 134a	Lt. 350	Kg 100
SKY 150 P COMBI	Watt 600	230v/1/50Hz	°C -15/-18 • °C -1/+5			R 134a	Lt. 350	Kg 100
SKY 200 P	Watt 633	230v/1/50Hz	°C -15/-18			R 134a	Lt. 518	Kg 125
SKY 200 P COMBI	Watt 633	230v/1/50Hz	°C -15/-18 • °C -1/+5			R 134a	Lt. 518	Kg 125
SKY 150 S	Watt 600	230v/1/50Hz	°C -15/-18			R 134a	Lt. 350	Kg 98
SKY 150 S COMBI	Watt 600	230v/1/50Hz	°C -15/-18 • °C -1/+5			R 134a	Lt. 350	Kg 98
SKY 200 S	Watt 633	230v/1/50Hz	°C -15/-18			R 134a	Lt. 518	Kg 123
SKY 200 S COMBI	Watt 633	230v/1/50Hz	°C -15/-18 • °C -1/+5			R 134a	Lt. 518	Kg 123

Dati di collaudo - Test details - Détails d'essai - Prüfungsergebnisse - Datos de ensayo - MAX = (30°C - % U.R. 55)

EUROLINE

BIRRA

MERCATI
SPECIALILABORATORI
PASTICCERIA

RISTORAZIONE

PIZZERIA

ESPOSIZIONE

SUPERMERCATI

HYPERMARKET

10

ATTREZZATURE COMPLEMENTARI

SKY MASTER 180 / SKY MASTER 180 COMBI

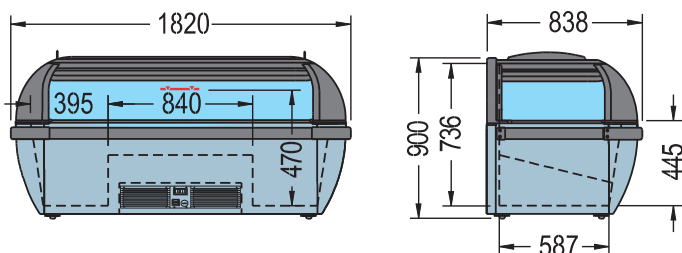

Profilo di protezione antiurto dei carrelli supermercato
Supermarket trolleys' shock-resistant protection profile / Profil de protection anti-choqs des chariots du supermarché / Stofffestes Schutzprofil gegen Einkaufswagen im Supermarkt / Perfil de protección contra choques de carros de supermercado

Isolamento con 70 mm di spessore
Insulation thickness 70 mm. / Isolation avec 70 mm d'épaisseur / Isolierung durch eine Dicke von 70 mm. / Aislamiento de 70 mm de espesor

Termostato regolabile
Adjustable thermostat / Thermostat réglable / Regulierbarer Thermostat / Termostato regulabile

Interno ed esterno in lamiera galvanizzata rivestita in PVC bianco
Interior and exterior made of galvanized sheet covered in white PVC / Intérieur et extérieur en tôle galvanisée recouverte de PVC blanc / Innen- und Außenseite aus galvanisiertem Blech und mit weißem PVC überzogen / Interior y exterior de chapa galvanizada revestida de PVC blanco

Termometro digitale per il controllo della temperatura interna
Digital thermometer to check internal temperature / Thermomètre digital pour le contrôle de la température interne / Digitaler Thermometer zur Kontrolle der Innentemperatur / Termómetro digital para controlar temperatura interna

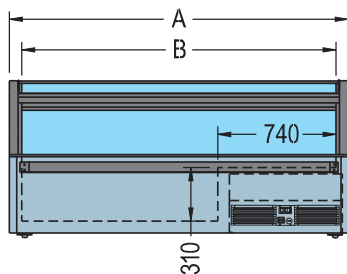
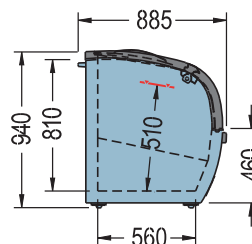
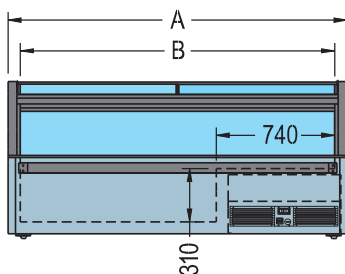
SKY P / SKY P COMBI
SKY S / SKY S COMBISKY 150 P / SKY 200 P
SKY 150 P COMBI / SKY 200 P COMBISKY 150 S / SKY 200 S
SKY 150 S COMBI / SKY 200 S COMBI

SKY S:

Forniti con 1 paio di coperchi scorrevoli in vetro termico curvo
Provided with 1 pair of sliding covers made of curved thermic glass / Fournis avec 1 paire de couvercles coulissants en verre thermique courbé / Mit 1 Paar Schiebedeckel aus gekrümmtem Wärmeschutzglas geliefert / Provistos con 1 par de tapas corredizas de cristal térmico curvo

DIMENSIONI / SIZE / DIMENSIONS / MAÑE / MEDIDAS

	A (mm)	B (mm)
SKY 150 P/SKY 150 P COMBI	1500	1360
SKY 200 P/SKY 200 P COMBI	2000	1860
SKY 150 S/SKY 150 S COMBI	1500	1360
SKY 200 S/SKY 200 S COMBI	2000	1860

Profilo di protezione antiurto dei carrelli supermercato
Supermarket trolleys' shock-resistant protection profile / Profil de protection anti-choqs des chariots du supermarché / Stofffestes Schutzprofil gegen Einkaufswagen im Supermarkt / Perfil de protección contra choques de carros de supermercado

Isolamento con 70 mm di spessore
Insulation thickness 70 mm. / Isolation avec 70 mm d'épaisseur / Isolierung durch eine Dicke von 70 mm. / Aislamiento de 70 mm de espesor

Interno ed esterno in lamiera galvanizzata rivestita in PVC bianco
Interior and exterior made of galvanized sheet covered in white PVC / Intérieur et extérieur en tôle galvanisée recouverte de PVC blanc / Innen- und Außenseite aus galvanisiertem Blech und mit weißem PVC überzogen / Interior y exterior de chapa galvanizada revestida de PVC blanco

Termostato regolabile
Adjustable thermostat / Thermostat réglable / Regulierbarer Thermostat / Termostato regulabile

Termometro digitale per il controllo della temperatura interna
Digital thermometer to check internal temperature / Thermomètre digital pour le contrôle de la température interne / Digitaler Thermometer zur Kontrolle der Innentemperatur / Termómetro digital para controlar temperatura interna

Illuminazione interna
Internal lighting / Eclairage interne / Innenbeleuchtung / Iluminación interna



9/1 ISOLE HYPER

252



GONDOLA WALL SG

NEW



Superficie espositiva
Display surface
Surfaces d'exposition
Ausstellungsoberfläche
Superficie expositiva

GONDOLA WALL 190 SG = m² 1,92
GONDOLA WALL 250 SG = m² 2,55
GONDOLA WALL 380 SG = m² 3,83
GONDOLA TOP SG = m² 2,16



GONDOLA 2V SG

NEW



Superficie espositiva
Display surface
Surfaces d'exposition
Ausstellungsoberfläche
Superficie expositiva

GONDOLA 2V 190 SG = m² 2,84
GONDOLA 2V 250 SG = m² 3,78
GONDOLA 2V 380 SG = m² 5,68

Modello Model Modèle Modell Modelo	Potenza Power Puissance Gesamtleistung Potencia	Tensione Tension Tension Spannung Tension	Temperatura Temperature Temperature Temperatur Temperatura	Refrigerazione Refrigeration Refrigeration Kuehlung Refrigeracion	Sbrinamento Defrosting Degivrage Enteisung Desescarche	Gas refrigerante Cooling gas Gaz réfrigérant Kühlgas Gas refrigerante	Capacità Capacity Capacité Gerraumvolumen Capacidad	Dimensioni mm. Size mm. Dimensions mm. Abmessungen mm. Medidas mm.	Peso netto Net weight Poids net Nettogewicht Peso neto
GONDOLA WALL 190 SG	Watt 750	230v/1/50Hz	°C -18/-22			R 404a	Lt. 670	mm. 2075x1130x890	Kg 925
GONDOLA WALL 250 SG	Watt 1000	230v/1/50Hz	°C -18/-22			R 404a	Lt. 890	mm. 2700x1130x890	Kg 300
GONDOLA WALL 380 SG	Watt 1500	230v/1/50Hz	°C -18/-22			R 404a	Lt. 1340	mm. 3950x1130x890	Kg 450
GONDOLA TOP SG	Watt 845	230v/1/50Hz	°C -18/-22			R 404a	Lt. 750	mm. 2312x1130x890	Kg 957

Dati di collaudo - Test details - Détails d'essai - Prüfungsergebnisse - Datos de ensayo - MAX = (25°C - % U.R. 60)

Tenda notte accessorio OPTIONAL
 Optional : Night curtain
 Rideau nuit comme accessoire Optional
 Nachtvorhang Zubehör OPTIONAL
 Cortina para la noche OPTIONAL



Vasca e pannello posteriore in lamiera zincata, isolamento in poliuretano
 Tank and rear panel in galvanized metal plate, polyurethane isolation
 Bac et panneau derrière en tôle galvanisée, isolation en polyuréthane
 Cuba y panel posterior en chapa galvanizada, aislamiento em poliuretano
 Wanne und hinteres Paneel aus verzinktem Blech, Isolierung aus Polyurethan

Ferma prodotti in vetro
 Product stopper in glass
 Ferme produit en verre
 Para productos en vidrio
 Produkt Stopper aus Glas

Batticarrello frontale e laterale
 Front and side bumper bar
 Protection anti-chocs frontale et latérale
 Front und Seiten Schutzstab
 Parachoque frontal y lateral

Divisori in filo (uno per ogni 625 mm)
 Wire dividers (one for each 625 mm)
 Intercalaires en fil (un chaque 625 mm)
 Separador en hilo (uno cada 625 mm)
 Trennelemente aus Draht (eins alle 625 mm)

Vetro triplo panoramico
 Panoramic triple glass
 Triple vitrage panoramique
 Dreifaches panoramisches Glas
 Vidrio triple panoramico

Lunghezza senza spalle
 Length without side panels
 Longueur sans panneaux latéraux
 Länge ohne Seitenwände
 Largo sin paneles laterales

GONDOLA WALL 190 SG = mm. 1875
GONDOLA WALL 250 SG = mm. 2500
GONDOLA WALL 380 SG = mm. 3750
GONDOLA TOP SG = mm. 2112

GONDOLA 2V 190 SG = mm. 1875
GONDOLA 2V 250 SG = mm. 2500
GONDOLA 2V 380 SG = mm. 3750

GONDOLA WALL SG

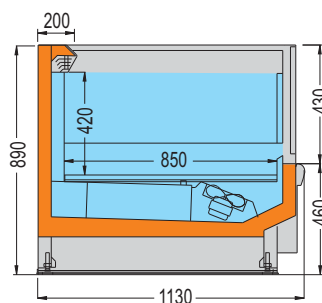

GONDOLA 2V SG

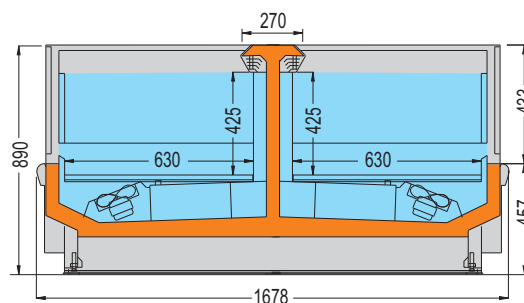

GONDOLA WALL SG

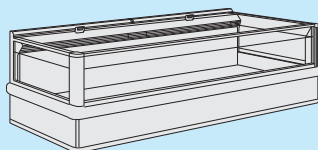

GONDOLA 2V SG

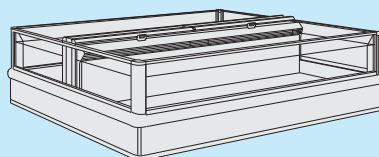

GONDOLA 2V + TOP SG

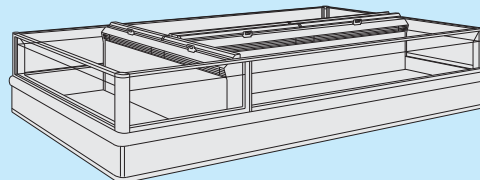

Modello
 Model
 Modèle
 Modell
 Modelo

Potenza
 Power
 Puissance
 Gesamtleistung
 Potencia

Tensione
 Tension
 Tension
 Spannung
 Tension

Temperatura
 Temperature
 Temperature
 Temperatur
 Temperatura

Refrigerazione
 Refrigeration
 Refrigeration
 Kuehlung
 Refrigeracion

Sbrinatorio
 Defrosting
 Degivrage
 Enteisung
 Desescarche

Gas refrigerante
 Cooling gas
 Gaz réfrigérant
 Kühlgas
 Gas refrigerante

Capacità
 Capacity
 Capacité
 Gerraumvolumen
 Capacidad

Dimensioni mm.
 Size mm.
 Dimensions mm.
 Abmessungen mm.
 Medidas mm.

Peso netto
 Net weight
 Poids net
 Nettogewicht
 Peso neto



Modello	Potenza	Tensione	Temperatura	Refrigerazione	Sbrinatorio	Gas refrigerante	Capacità	Dimensioni mm.	Peso netto
GONDOLA 2V 190 SG	Watt 750	230v/1/50Hz	°C -18/-22			R 404a	Lt. 1000	mm. 2074x1678x890	Kg 450
GONDOLA 2V 250 SG	Watt 1000	230v/1/50Hz	°C -18/-22			R 404a	Lt. 1340	mm. 2700x1678x890	Kg 600
GONDOLA 2V 380 SG	Watt 1500	230v/1/50Hz	°C -18/-22			R 404a	Lt. 2000	mm. 3950x1678x890	Kg 900

Dati di collaudo - Test details - Détails d'essai - Prüfungsergebnisse - Datos de ensayo - MAX = (25°C - % U.R. 60)