

# TPWX2GD "HAZARDOUS ZONE" SERIES PALLET TRUCK SCALE ATEX

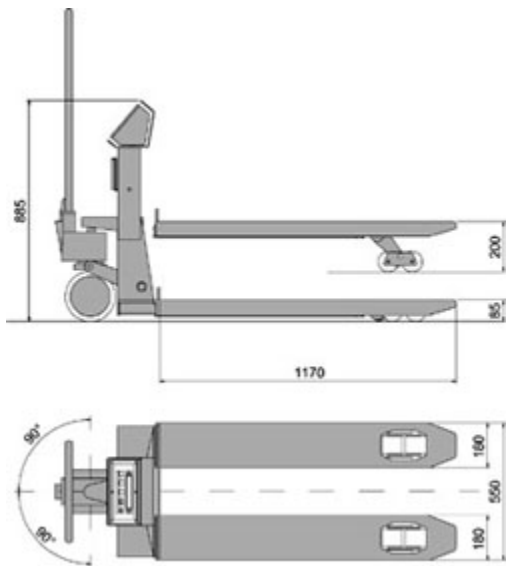

TPWX con forche INOX opzionali.



dimensioni in mm

**Pallet truck scales, with built-in electronic weighing, for dangerous areas classified as hazardous (ZONES 1 and 21 & 2 and 22) in accordance with Ex II2GD IIB T4T197°CX.**

**The ATEX certified four load cell weight detection IP68 guarantees the best accuracy in all work conditions. Available also CE-M APPROVED.**

## MAIN FEATURES

Maximum lifting capacity: 2500 kg.

Accuracy: +/- 0.05% of the maximum capacity.

Fork dimensions 1150 x 550 x 85 mm.

Weighs about 125 kg.

Bearing structure in extra thick sheet steel and oven -fire painted interior construction.

### Standard fitted swivelling column head .

Steering wheels and double loading rollers with a poliurethane coating.

ATEX certified, 4 stainless steel IP68 shear -beam load cells.

Indicator with easy to clean **satined stainless steel case with IP68** enclosure built to withstand humid and dusty environments large LCD display 25 -mm high contrast digits which are clearly visible even in poor lighting conditions 17 -key numerical/functional membrane waterproof keyboard.

Calibration and Set-Up parameters configurable from keyboard.

Power supply through extractable battery, rechargeable in safe zone.

150-h our approximate operating time.

Equipped with 230 Vac 50 Hz battery charger to be recharged in a safe area.

## SELECTABLE FUNCTIONS

### High Resolution

### Weighing x 10

### Net/Gross or lb/kg conversion Weighs accumulation

### Formulation

### Counting In/Outweighing

### Hold.

## KEYBOARD FUNCTION

- Zeroing, Automatic Tare, Presettable Tare, ID1 and ID2 10 -digit Codes, Print and data transmission commands, selectable function command, on/off switching

## OPTIONSONLYAVAILABLEATTHE TIME OF ORDER

Rechargeable battery kit. Parking brake system with command pedal mounted on steering wheels. 680mm fork width (ask for price estimate). Special fork length from 850 to 1500mm (ask for price estimate). 3000 kg capacity (ask for price estimate). Special models, sizes or high resolution (ask for estimate). Special wheels available with price estimate.



**WARNING With ATEX weighing systems, when directly weighing light metals, it is necessary to use the STAINLESS STEEL forks.**

Code	Max Capacity kg	Division kg	CE-M Division kg	Price €
TPWX2GD20	500/1000/2000	0,2/0,5/1		3.880.00
TPWX2GD20M <b>M</b>	1000/2000		0,5/1	4.270.00
TPWX2GD15M <b>M</b>	600/1500		0,2/0,5	5.530.00
TPWX2GD25	600/1500/2500	0,2/0,5/1		5.140.00
TPWX2GD25M <b>M</b>	1500/2500		0,5/1	6.180.00

Code	Description	Price €
TPWXFI	Pair of stainless steel forks.	1.170,00
DFWBP76ATEX	Rechargeable ATEX battery from 9,6 Vdc and 7600 mAh for weight indicator, pallet truck scale, or crane scale. NOTE: Recharge of the battery pack allowed only in a safe area. In the applications with the weight indicator mounted on a column or cart, the installation requires the STFA bracket.	620,00
TPWFRE	Parking brake system with command pedal mounted on steering wheels.	210,00

# TPWX2GDI "HAZARDOUS ZONE" SERIES STAINLESS STEEL ATEX PALLET TRUCK SCALE



Pallet truck scales, with built-in electronic weighing, for dangerous areas classified as hazardous (ZONES 1 and 21 & 2 and 22) in accordance with Ex II2GD IIB T4T19°CX. The weight detection made with four Atex certified IP68 stainless steel load cells guarantees the best precision in all work conditions.

Structure completely in STAINLESS steel.  
Available also CE-M APPROVED.

## MAIN FEATURES

- Maximum lifting capacity: 2000 kg.
- Accuracy: +/- 0.1% of the maximum capacity.
- Fork dimensions 1182 x 550 x 80 mm.
- Weighs about 135 kg.
- Bearing structure entirely in extra thick sheet steel .**
- Lifting pump in STAINLESS steel .**
- Steering wheels with rubber coating.
- Double loading rollers with a polyurethane coating.
- 4 stainless steel IP68 Atex certified shear –beam load cells.
- Weight indicator with **waterproof IP68 STAINLESS STEEL case**, easy to clean and resistant to harsh and corrosive environments large high contrast 25 mm LCD display, easily visible also in poor lighting conditions and water proof membrane keypad, with 17 numerical/functional keys.
- Calibration and Set-Up parameters configurable from keyboard.
- Power supply through extractable battery, rechargeable in safe zone.
- 150-hour approximate operating time.
- Equipped with 230 Vac 50 Hz battery charger to be recharged in a safe area.

TPWX2GDI: pallet truck scale in STAINLESS steel, for hazardous areas.

## SELECTABLE FUNCTIONS

- High Resolution Weighing x 10 Net/Gross or lb/kg conversion
- Formulation
- Counting
- In/Out weighing
- Hold.

## KEYBOARD FUNCTION

Zeroing, Automatic Tare, Presetable Tare, ID1 and ID2 10 –digit Codes, Print and data transmission commands, selectable function command, on/off switching

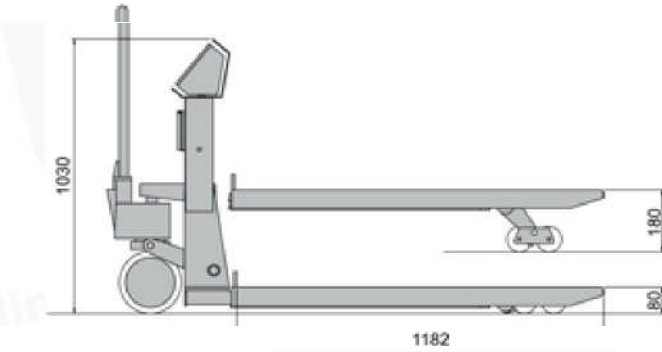

## OPTIONSONLYAVAILABLEATTIMEOFORDER

Rechargeable battery kit. Parking brake system with command pedal. 680 mm fork width (ask for price estimate). Special fork length from 850 to 1500 mm (ask for price estimate). 3000 kg capacity (ask for price estimate). Special models, sizes or high resolution (ask for estimate). Special wheels available with price estimate.

Code	Max Capacity kg	Division kg	CE-M Division kg	Price €
TPWX2GDI20	500/1000/2000	0,2/0,5/1		7.800,00
TPWX2GDI20M	1000/2000		0,5/1	8.190,00

Code	Description	Price €
DFWBP76ATEX	Rechargeable ATEX battery from 9,6 Vdc and 7600 mAh for weight indicator, pallet truck scale, or crane scale. NOTE: Recharge of the battery pack allowed only in a safe area. In the applications with the weight indicator mounted on a column or cart, the installation requires the STFA bracket.	620,00
TPWIFRE	Parking brake system with command pedal for stainless steel pallet truck scales, mounted on steering wheels.	780,00

# TPWX3GD "HAZARDOUS ZONE" SERIES ATEX PALLET TRUCK SCALE



Pallet truck scales, with built-in electronic weighing, suitable for harsh working conditions and dangerous areas classified as hazardous (ZONE 2, 22) in accordance with Ex II3GD IIC T6 T130°C X protection. The ATEX certified four load cell weight detection guarantees the best accuracy in all work conditions. Available also CE-M APPROVED.

## MAIN FEATURES

- | Maximum lifting capacity:2000Kg.
- | Accuracy: +/- 0.1% of the maximum capacity.
- | Fork dimensions 1150 x 550 x 85 mm.
- | Weighs about 120 kg.
- | Bearing oven-fire painted structure in extra thick sheet steel.
- | **Standard fitted swivelling column head .**
  - | Steering wheels and double loading rollers with a poliurethane coating.
  - | ATEX certified, 4 stainless steel IP68 shear-beam load cells.
  - | Indicator with easy to clean **satined stainless steel case with IP68** enclosure built to withstand humid and dusty environments large LCD display 25-mm high contrast digits which are clearly visible evening poor lighting conditions 17 – key numerical/functional membrane waterproof keyboard.
  - | Calibration and Set-Up parameters configurable from keyboard.
  - | Power supply through extractable battery ,rechargeable in safe zone.
  - | 40-hour approximate operating time.
  - | Programmable automatic switch -off.
  - | Battery level indication.
  - | Equipped with 230Vac50Hz battery charger to be recharged in a safe area.

## SELECTABLE FUNCTIONS

### High Resolution

### Weighing x10

### Net/ Gross or lb/ kg conversion

### Accumulation

### Formula weighing

### +/- Checkweighing

### Percentage weighing

### Counting(Max.resolution of 1.500.000 divisions)

### In/Out Truck weighing

### Hold and Peak

**Peer-to-peer**(up to 4 remote connectable indicators)

**SetPoint Control** (with optional interface)

|Zeroing, Automatic tare, Presetable tare, Print and/or data transmission command, Function command.

## OPTIONS ONLY AVAILABLE AT TIME OF ORDER

Alibi memory with time -date.

Time-Date.

Parking brake system with command pedal mounted on steering wheels.

Set of steering wheels in Vulkolan (nonstainable). 680 mm fork width(ask for price estimate). Special fork length from 850 to 1500 mm(ask for price estimate). 3000 kg capacity(ask for price estimate). Special models and sizes(ask for estimate). Special wheels available with price estimate.

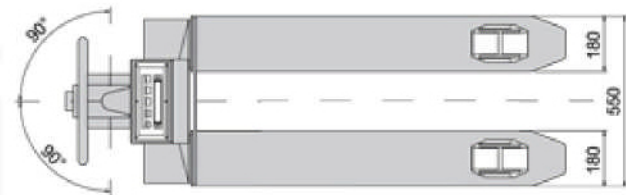
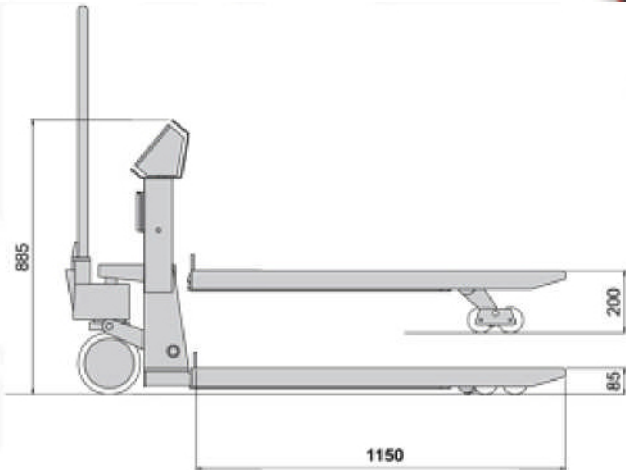

Dimensions in mm

Code	Max Capacity kg	Division kg	CE-M Division kg	Price €
TPWX3GD	500 / 1000 / 2000	0,2 / 0,5 / 1		2.580.00
TPWX3GDM	1000 / 2000		0,5 / 1	2.970.00



**WARNING**  
With ATEX weighing systems, when directly weighing light metals, it is necessary to use the **STAINLESS STEEL** forks.

<b>Code</b>	<b>Description</b>	<b>Price €</b>
TPWXF1	Pair of stainless steel forks.	1.170,00
TPWBKB3GD	Additional extractable battery for using the scale 24/7. NOTE: recharge and substitution of the battery allowed only in a safe area.	140,00
DFCLK	Clock and calendar for printing/displaying of the date and time.	90,00
ALMEM	Alibi memory (fiscal memory, max 120.000 weighs) for approved transmission of the weight. Clock/calendar integrated for print of the date/time.	170,00
RTV2	Set of steering wheels in Vulkolan (nonstainable).	200,00
TPWFRE	Parking brake system with command pedal mounted on steering wheels.	210,00

# TPWX3GDI "HAZARDOUS ZONE" SERIES STAINLESS STEEL ATEX PALLET TRUCK SCALE



**Pallet truck scales, with built-in electronic weighing, suitable for harsh working conditions and dangerous areas classified as hazardous (ZONE 2, 22) in accordance with Ex II3GD IIC T6 T130°C X protection. The weight detection made with four Atex certified IP68 stainless steel load cells guarantees the precision in all work conditions. Structure entirely in stainless steel Available also CE-M APPROVED.**

## MAIN FEATURES

- Maximum lifting capacity :2000 Kg.
- Accuracy: +/- 0.1% of the maximum capacity.
- Fork dimensions 1182 x 550 x 80 mm.
- Weighs about 135 kg.
- Bearing structure entirely in extra thick STAINLESS steel.**
- Lifting pump in STAINLESS steel .**
- Steering wheels with rubber coating.
- Double loading rollers with a polyurethane coating.
- Four IP68 STAINLESS steel,Atex certified,shear –beam load cells.
- Weight indicator with **waterproof IP68 STAINLESS STEEL case** ,easy to clean and resistant to harsh and corrosive environments large high contrast 25 mm LCD display,easily visible also in poor lighting conditions and waterproof membrane keypad, with 17 numerical/functional keys.
- Calibration and Set-Up parameters configurable from keyboard.
- Power supply through rechargeable battery,40 –hour approximate operating time.
- Low battery warning.Programmable auto switch -off.
- Equipped with 230Vac 50Hz battery charger to be recharged in a safe area.

TPWX3GDI: pallet truck scale in STAINLESS steel, for hazardous zones.

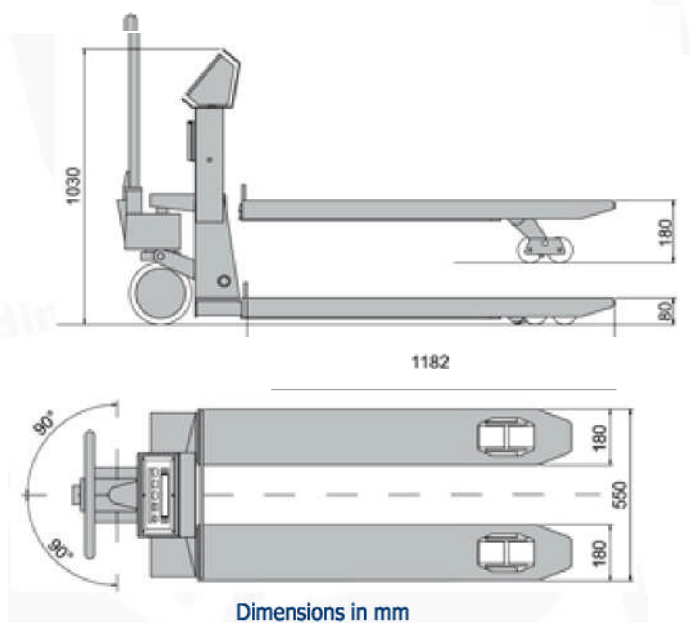

## SELECTABLEFUNCTIONS

**High Resolution**

**Weighing x 10**

**Net/Gross or lb/kg conversion Accumulation Formula weighing +/-Check weighing Percentage weighing**

**Counting** (Max .resolution of 1.500.000 divisions)  
**In/Out Truck weighing**

**Hold and Peak Peer-topeer**(up to 4 remote connectable indicators) **SetPoint Control** (with optional interface)

## KEYBOARD

Zeroing, Automatic tare, Presetable tare, Print and/or data transmission command, Function command.

Alibi memory with time -date.

Time-Date. Parking brake system with command pedal. 680 mm fork width(ask for price estimate). Special fork length from 850 to 1500 mm(ask for price estimate). 3000 kg capacity(ask for price estimate). High resolution version(ask for estimate). Special wheels available with price estimate.

Code	Max Capacity kg	Division kg	CE-M Division kg	Price €
TPWX3GDI20	500 / 1000 / 2000	0,2 / 0,5 / 1		5.850,00
TPWX3GDI20M	1000 / 2000		0,5 / 1	6.240,00

Code	Description	Price €
DFCLK	Clock and calendar for printing/displaying of the date and time.	90,00
ALMEM	Alibi memory (fiscal memory, max 120.000 weighs) for approved transmission of the weight. Clock/calendar integrated for print of the date/time.	170,00
RTV2	Set of steering wheels in Vulkolan (nonstainable).	200,00
TPWIFRE	Parking brake system with command pedal for stainless steel pallet truck scales, mounted on steering wheel	780,00