

FLYWHEEL SLICER F300 VO

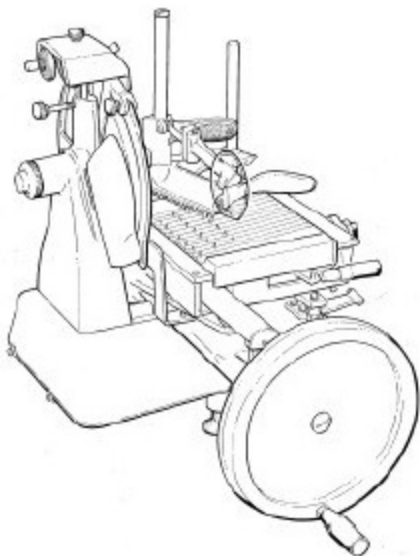

USE AND MAINTENANCE

Technical features

Blade diameter	300 mm
Cut thickness	0÷2 mm
Cut:	
-Width	230 mm
-Height	190 mm

Maximum overall dimensions (values in mm)

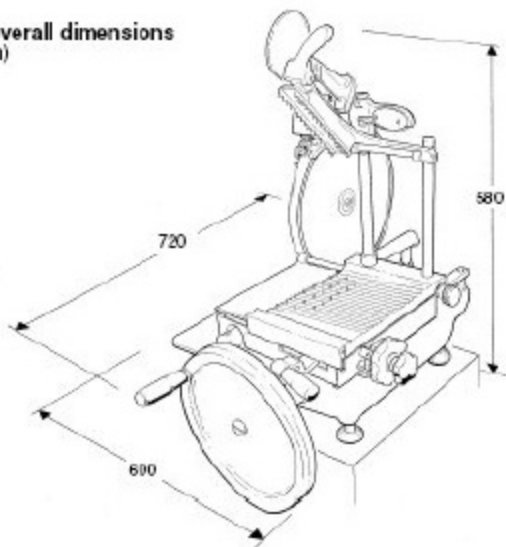

Overall dimensions and weight

Length	720 mm
Width	600 mm
Height	580 mm
Weight	45,5 kg
Distance between the feet	400x340 mm

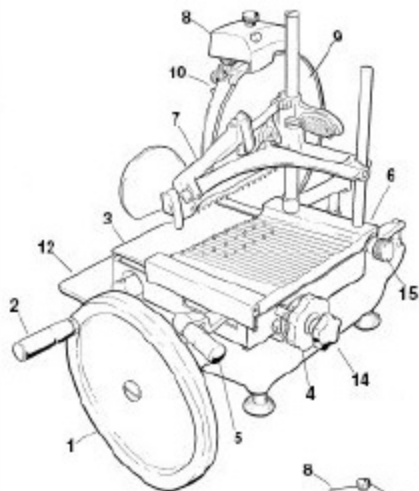

1. Flywheel
2. Handle
3. Carriage
4. Slice thickness gauge
5. Tray fast travel lever
6. Product tray
7. Product grip
8. Blade sharpener
9. Lama
10. Blade protection
11. Slice guide
12. Slice receiving tray
13. Waste tray
14. Tray slow travel
15. Tray locking knob
16. Blade sharpener locking knot

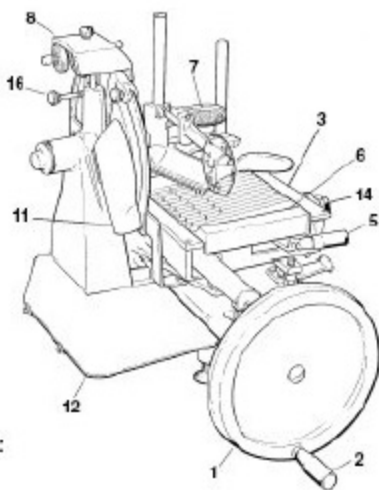

Machine operation

Turn the flywheel 1 drawing the carriage 3 (towards the operator);
Pull up the product grip 7;

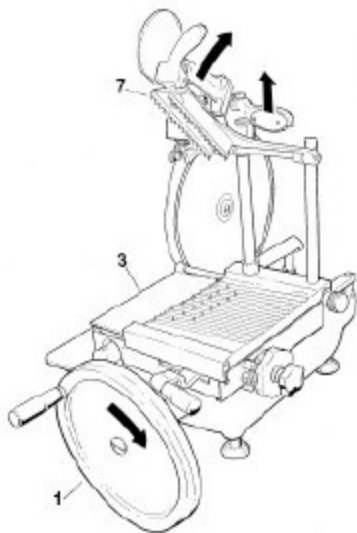

Place the product to be sliced on
the tray 6;

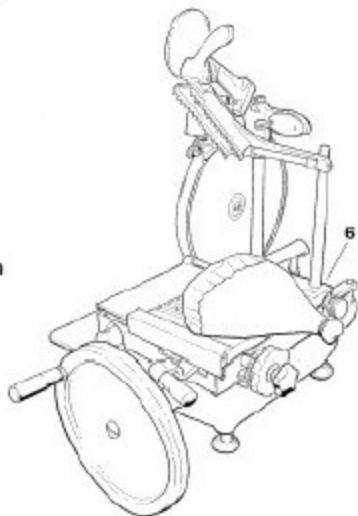

Lower the product grip 7 to hold the product;

Lower the lever 5 and move it to draw the product near the blade 9;

Drawing the product near the blade or away can be carried out more precisely using the knob 14;

Set up the slice thickness desired by operating the graduated knob 4 (0-2 mm);

Turn the flywheel 1 to start slicing and placing the slices on the tray 12.

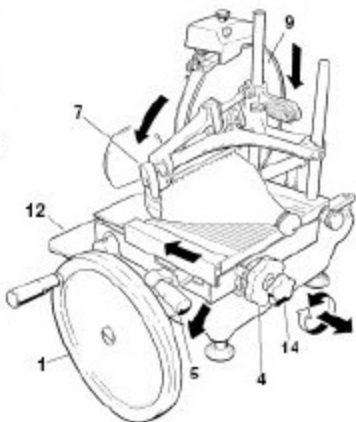

Cleaning the machine

Warning: Always wear non-scratch and anti-skid protection gloves when carrying out the operations described above. Always operate with great care and avoid any distraction.

DANGER OF CUTS!

Remove the product from the tray 6;

Turn the flywheel 1 by drawing the carriage 3 near the operator;

Press the lever 5 down and at the same time to the right;

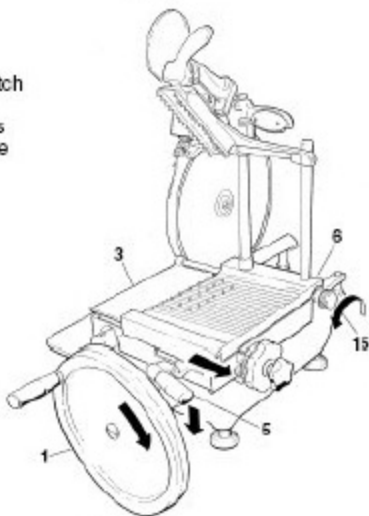

Extract the tray 6;
Clean the its lower part and the carriage 3 surface
carefully;



Clean the blade 9 as shown in
the image, with great care and
starting from the center to the
edge;



Open the slice guide 11 and clean
inside carefully;

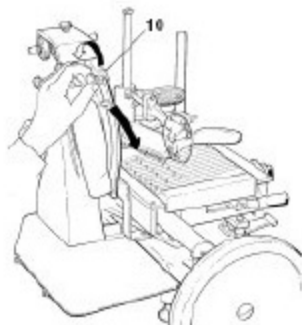
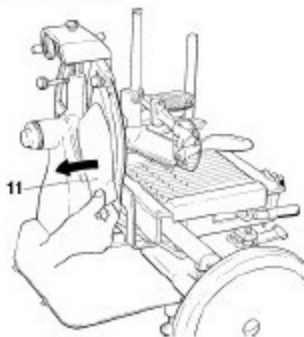

Remove the blade protection 10 after
loosening the locking knob.
WARNING: Danger of cuts!
After cleaning, reassemble the blade
protection immediately.

Extract the waste tray 13; wash, dry and put it again in its seat.

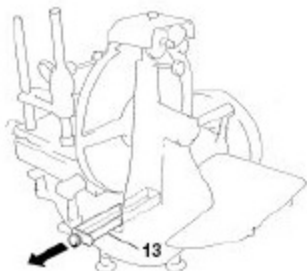
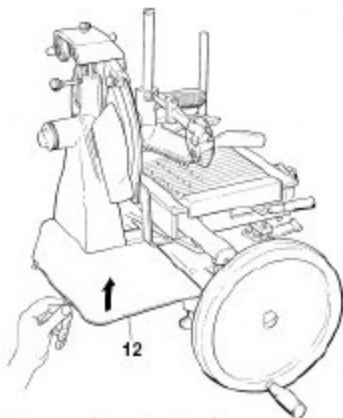

Remove the tray 12 after loosening the two fixing screws. To clean only use a cloth dampened with water and normal dishwashing liquid soap.

Sharpening the blade

Loosen the sharpener (8) locking knob;
Pull the sharpener up and turn it by 180°.

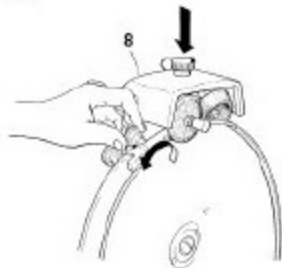

Lower the sharpener 8 back carefully, the blade will be automatically centered between the two grinding wheels.
Lock up the knob

Turn the flywheel and press the 8.1 button at the same time for 10-15 seconds; Stop rotation and use a pencil to check whether a slight burr has formed on the blade edge; Turn the flywheel again and press the 8.2 button for 2-3 seconds; Return the sharpener to its original position.

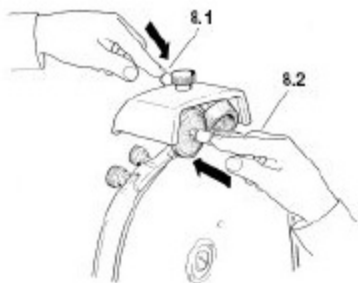

Lubrication

Add one or two oil drops at the points as shown.

Use only the oil supplied with the machine

After lubrication, clean carefully and remove the extra oil if necessary.

